

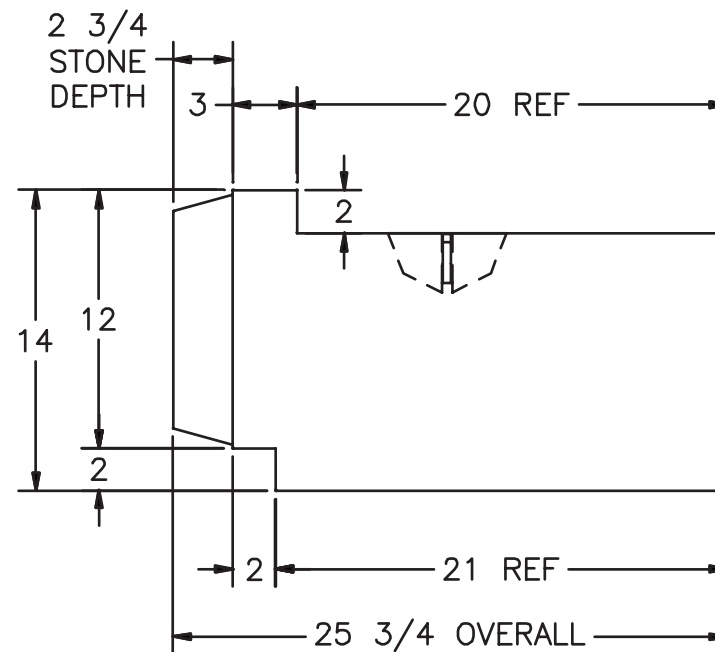

**MID-SIZE LANDSCAPE
SPECIFICATION
SHEETS**

■ MID-SIZE FULL BLOCK

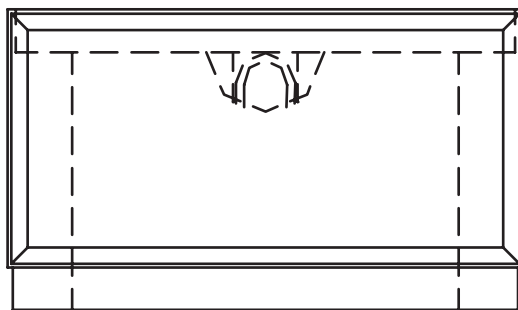
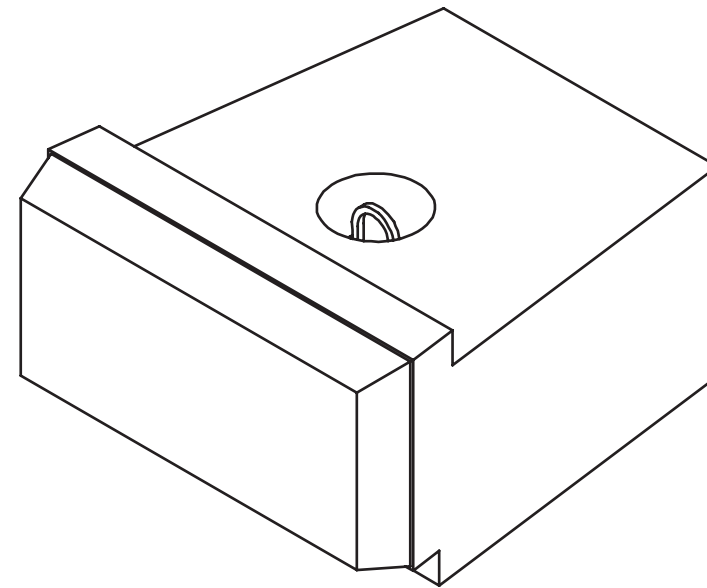
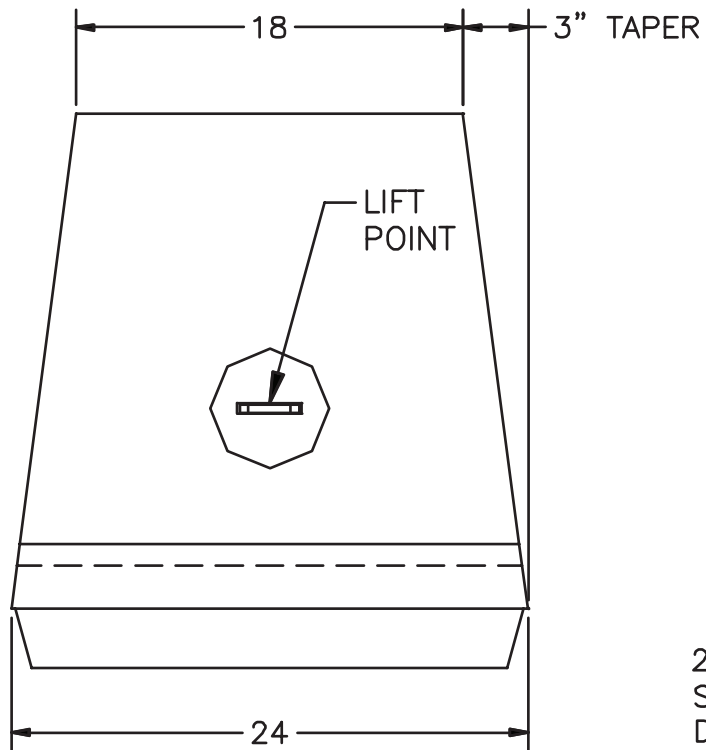

WEIGHT: 560 Lbs.
VOLUME: 3.75 Cft

■ MID-SIZE HALF BLOCK

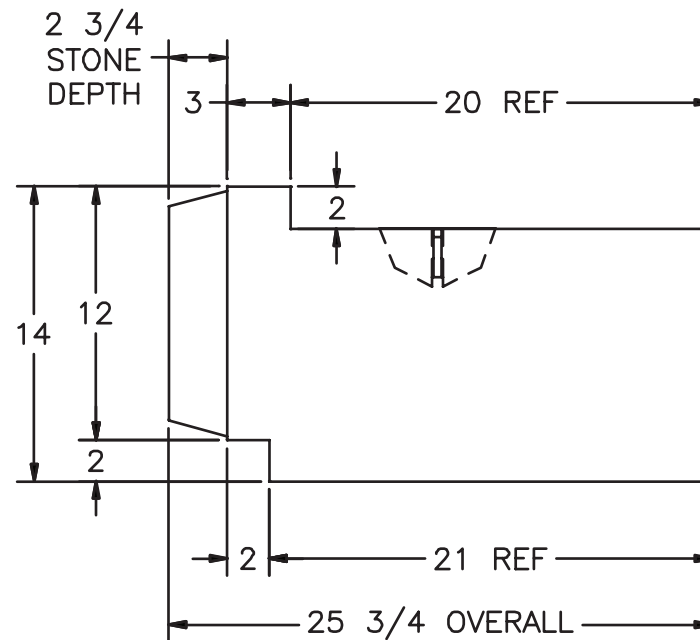
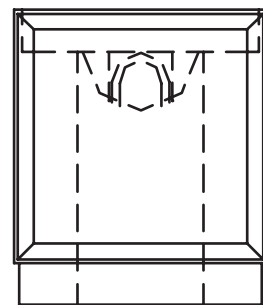
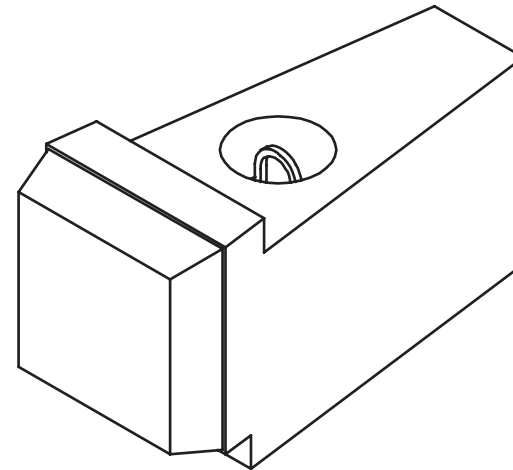
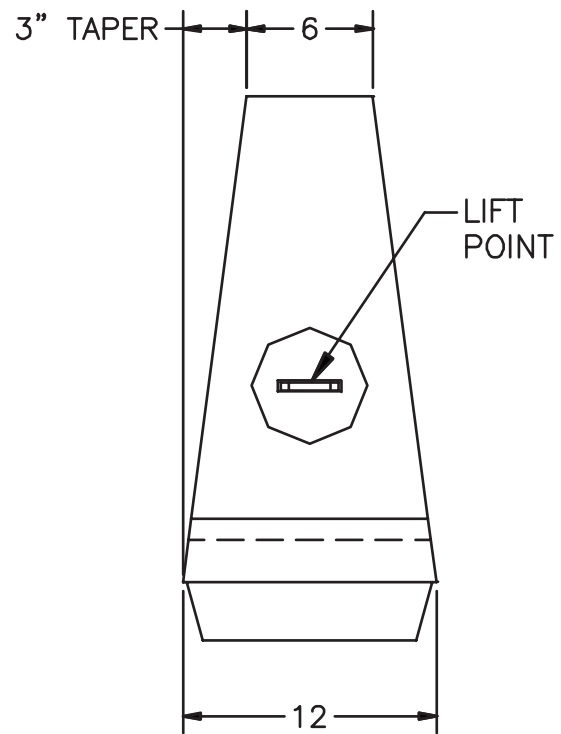

WEIGHT: 285 Lbs.
VOLUME: 1.9 Cft

■ MID-SIZE 4-ACROSS BLOCK

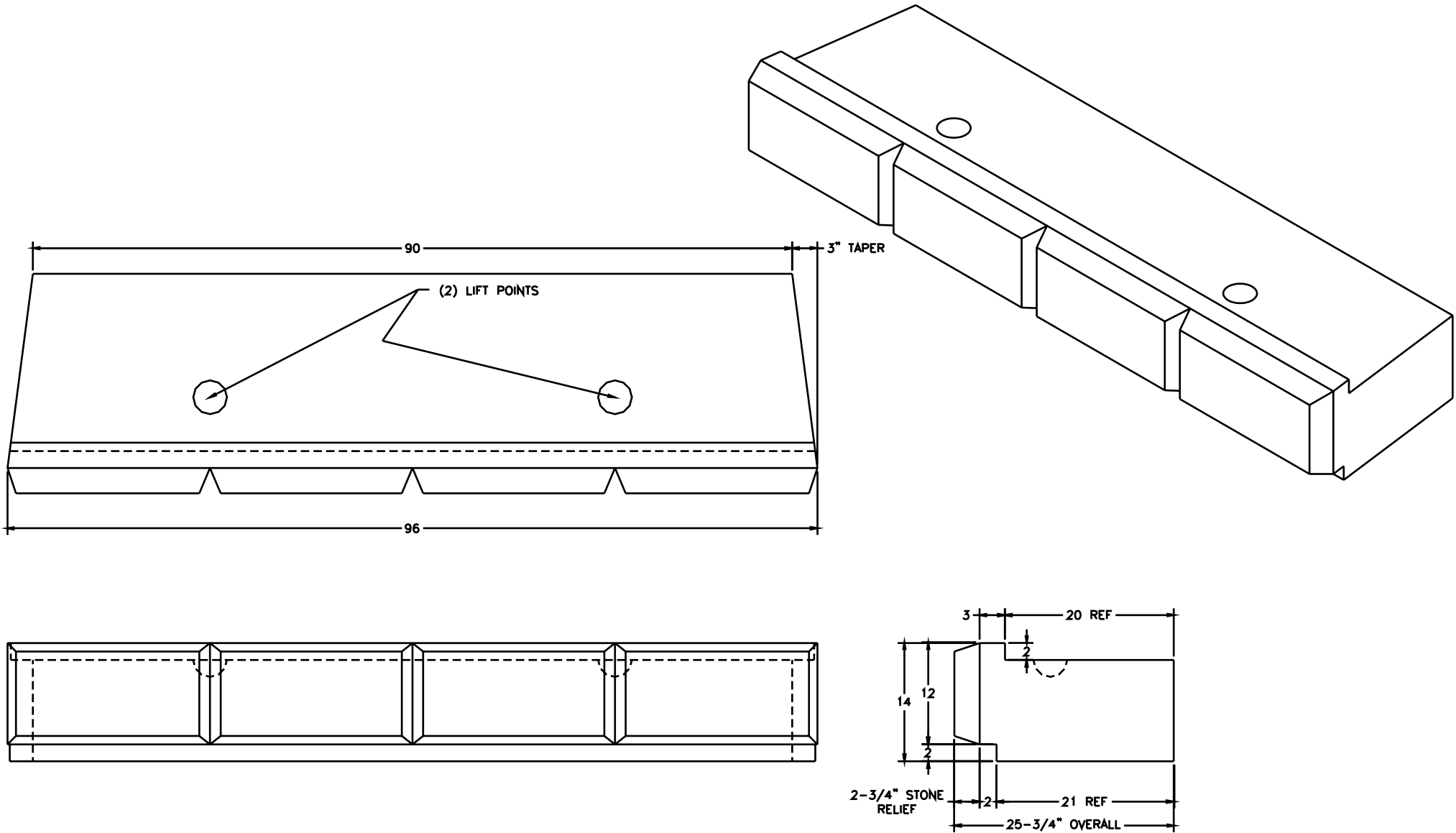

WEIGHT: 2,500 Lbs.
VOLUME: 16.67 Cft

■ MID-SIZE KEY BLOCK

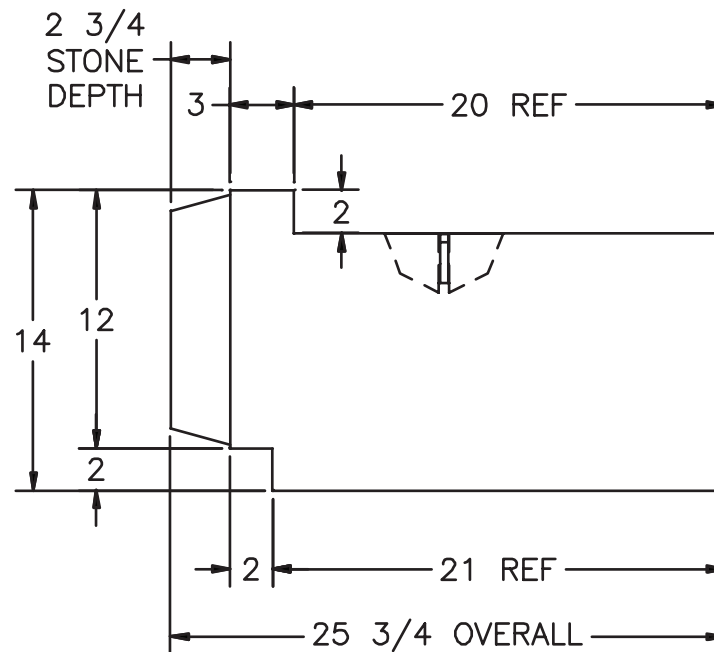
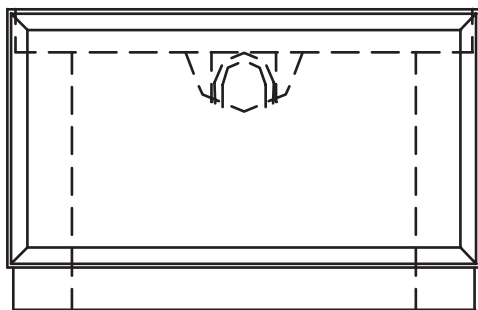
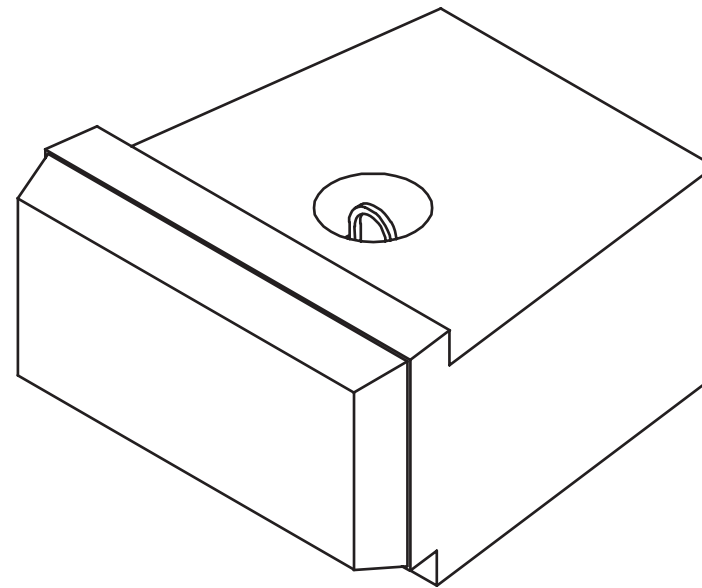
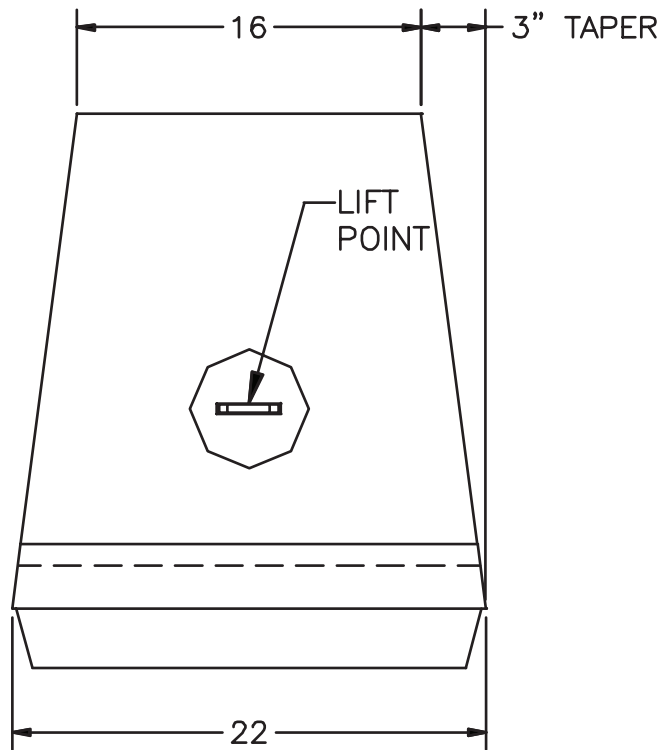

WEIGHT: 513 Lbs.
VOLUME: 3.42 Cft

■ MID-SIZE CORNER BLOCK (RIGHT)

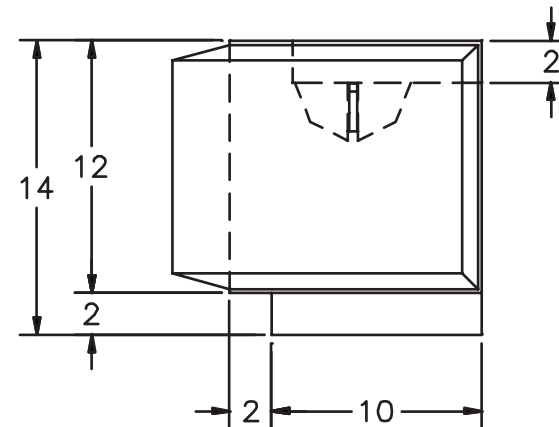
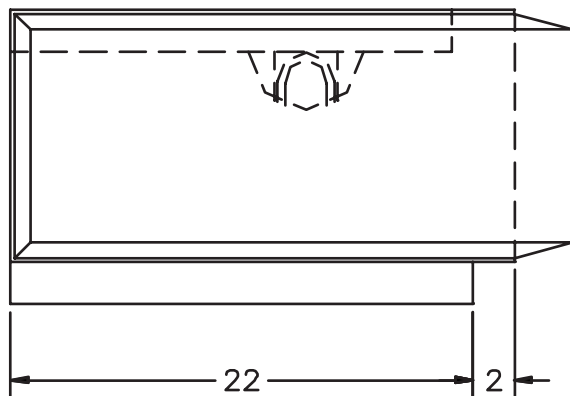
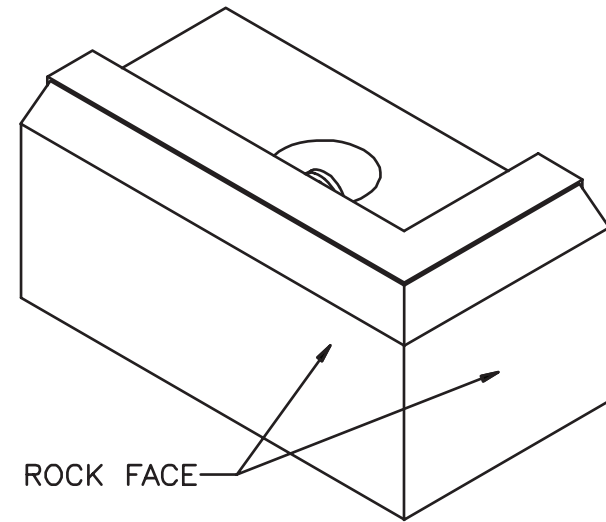
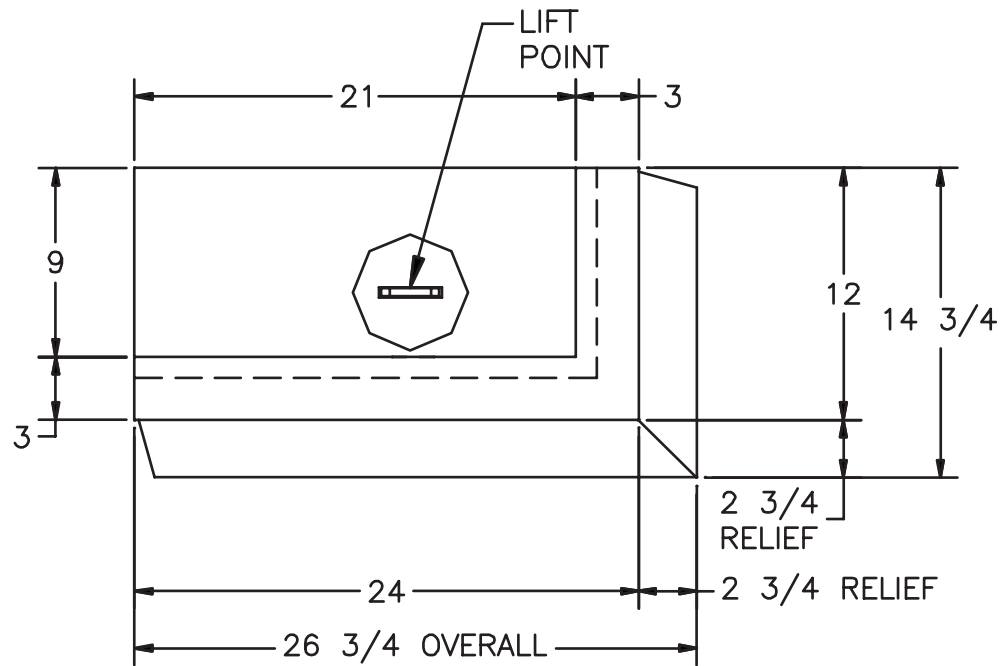

WEIGHT: 405 Lbs.
VOLUME: 2.70 Cft

■ MID-SIZE CORNER BLOCK (LEFT)

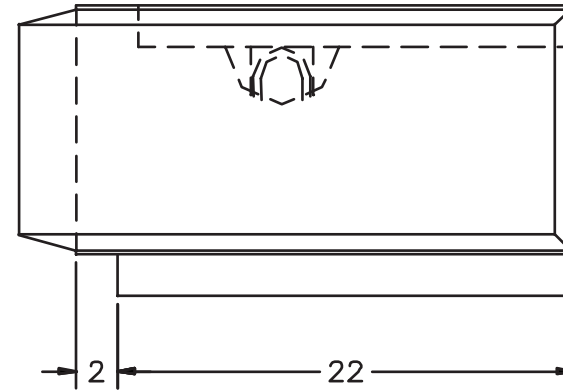
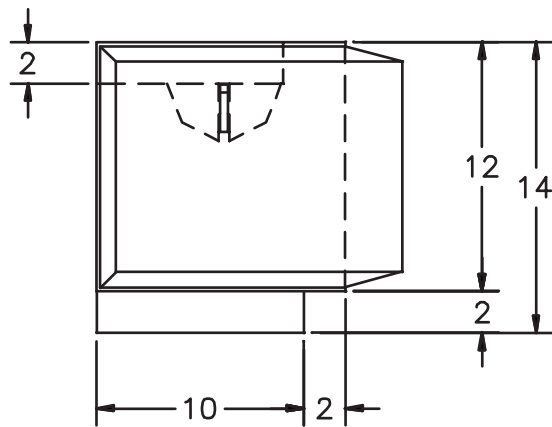
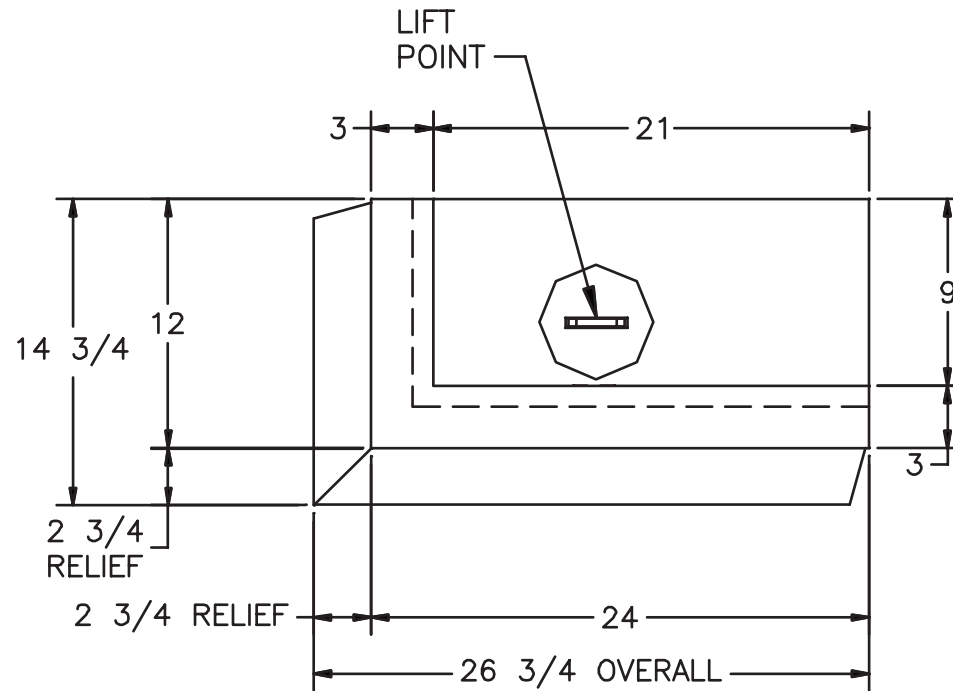
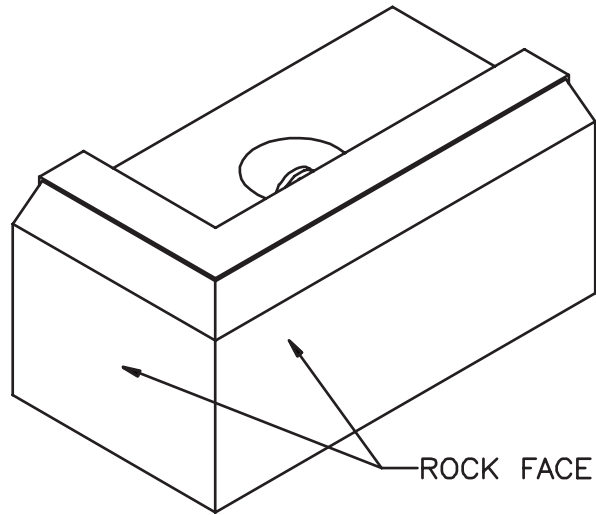

WEIGHT: 405 Lbs.
VOLUME: 2.70 Cft

■ MID-SIZE FULL RECESS BLOCK

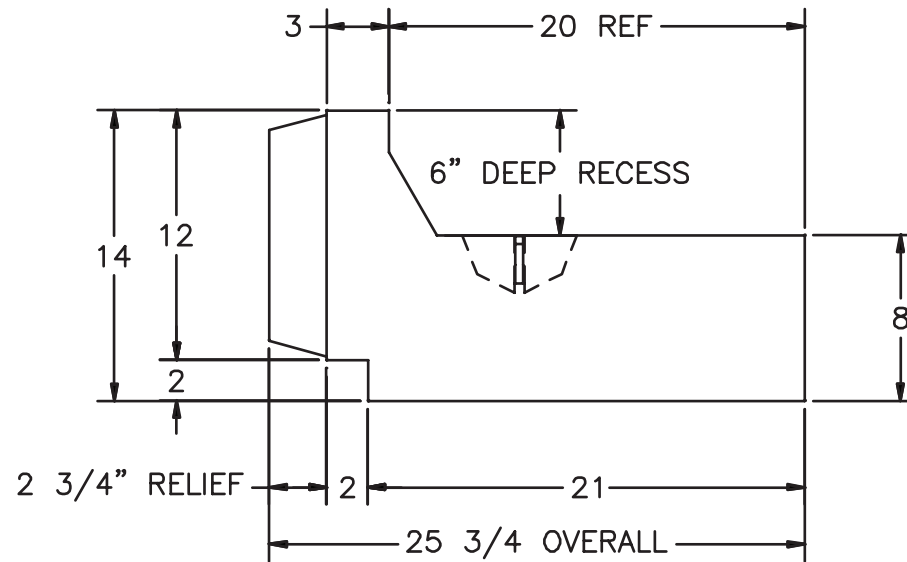
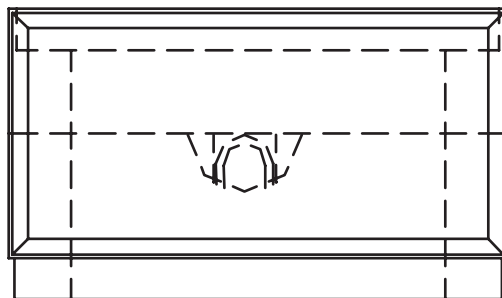
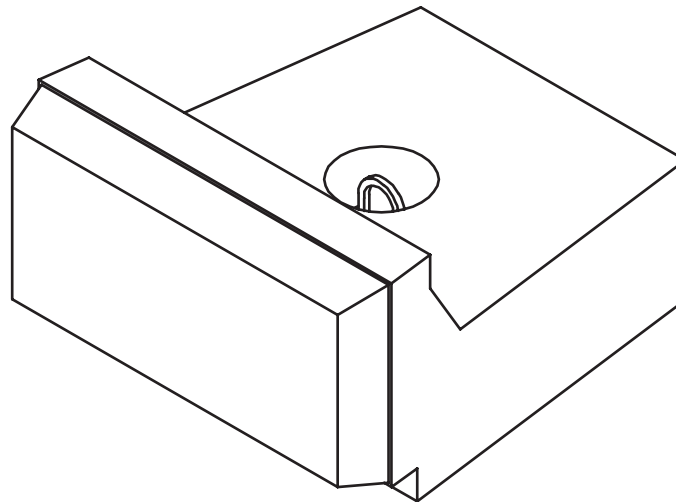
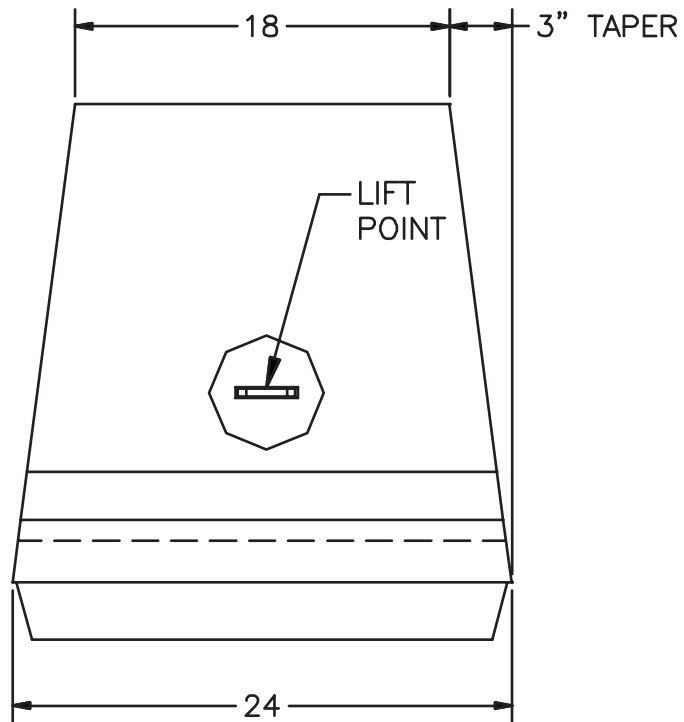

WEIGHT: 425 Lbs.
VOLUME: 2.80 Cft

■ MID-SIZE HALF RECESS BLOCK

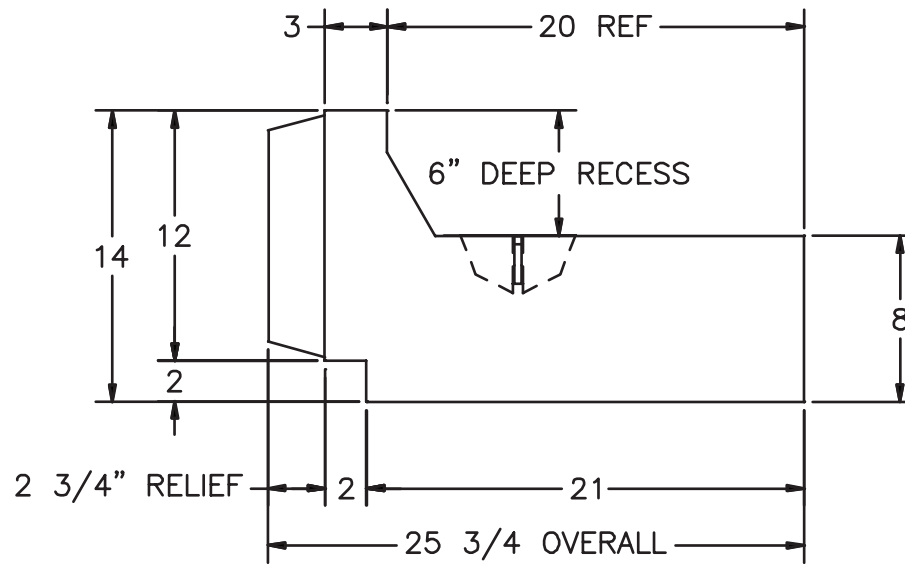
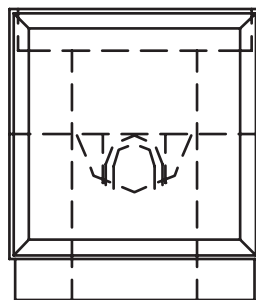
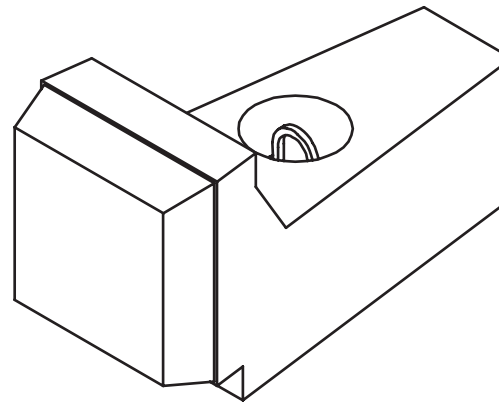
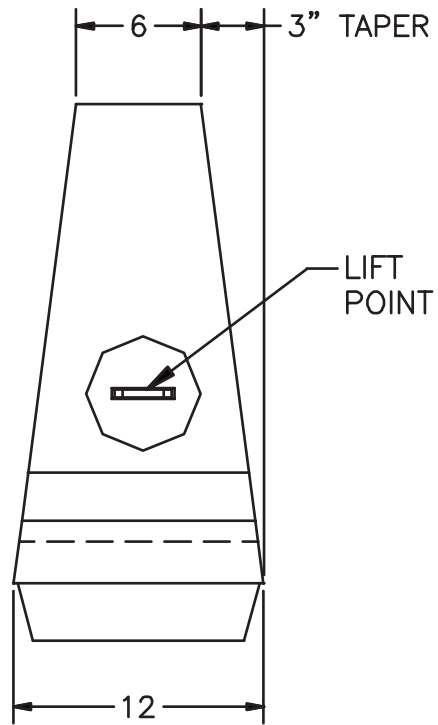

WEIGHT: 190 Lbs.
VOLUME: 1.27 Cft

■ MID-SIZE 4-ACROSS RECESS BLOCK

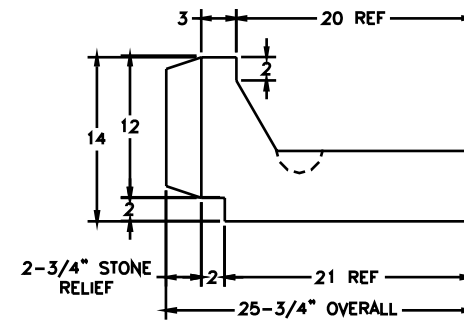
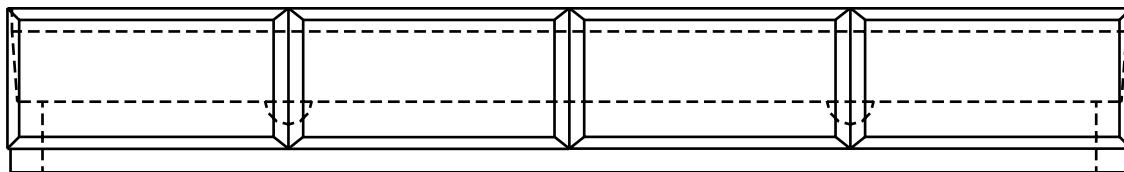
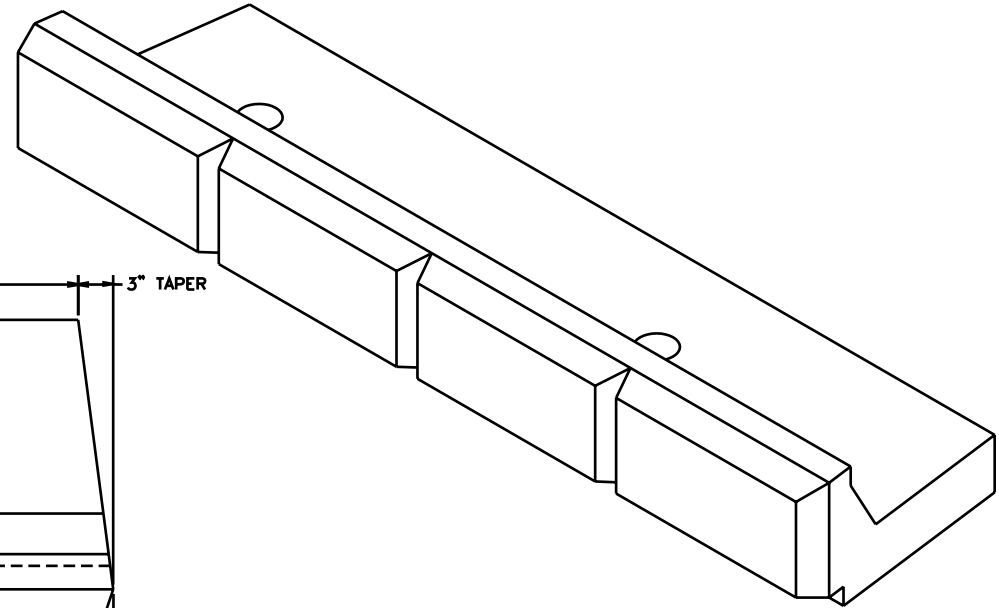
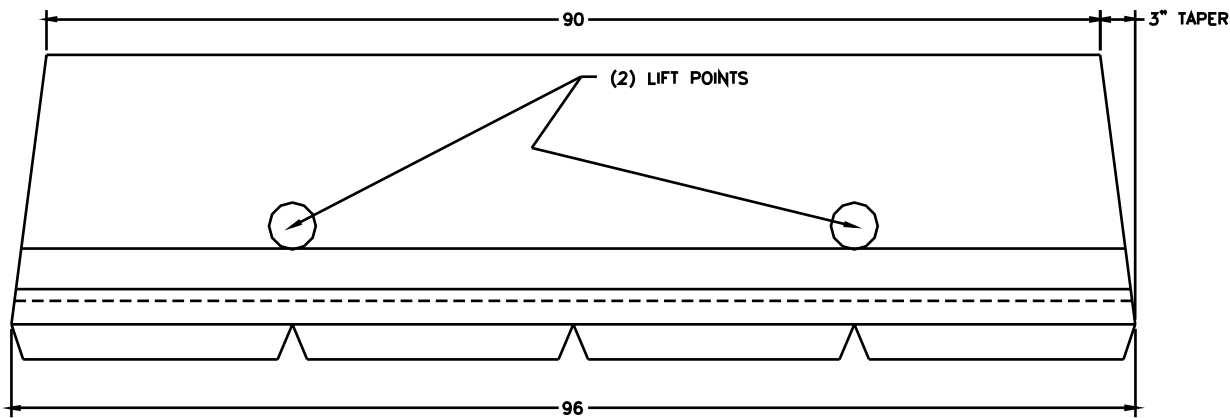

WEIGHT: 1,615 Lbs.
VOLUME: 10.75 Cft

■ MID-SIZE CORNER RECESS BLOCK (RIGHT)

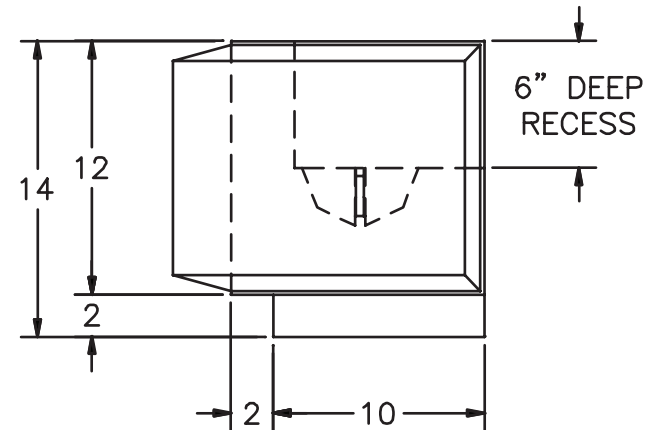
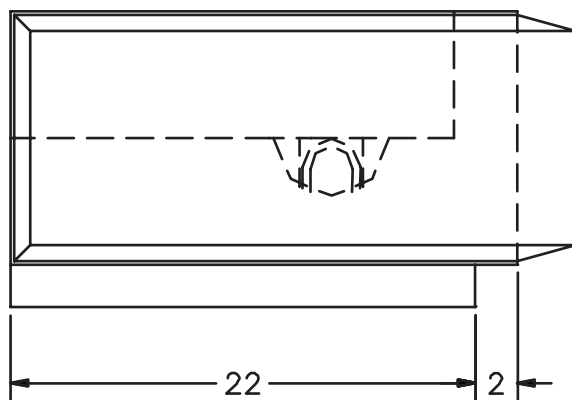
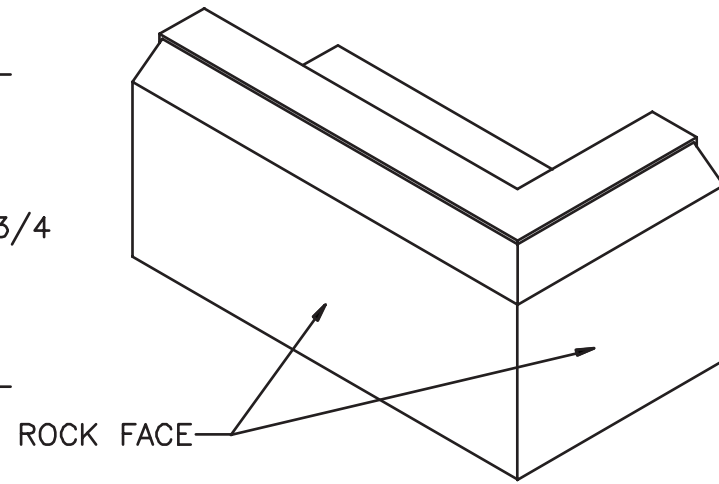
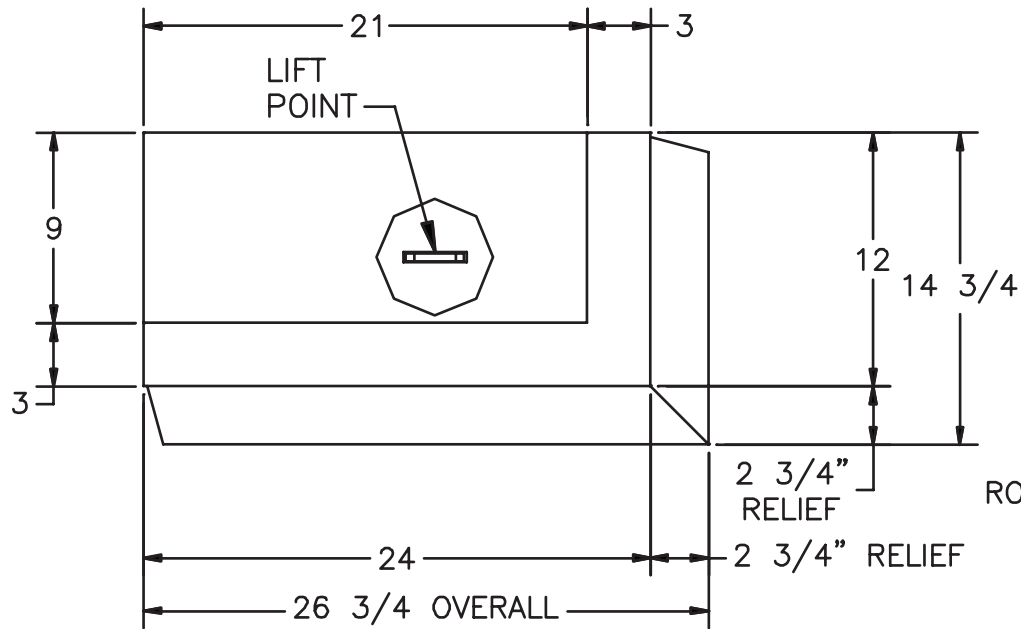

WEIGHT: 345 Lbs.
VOLUME: 2.30 Cft

■ MID-SIZE CORNER RECESS BLOCK (LEFT)

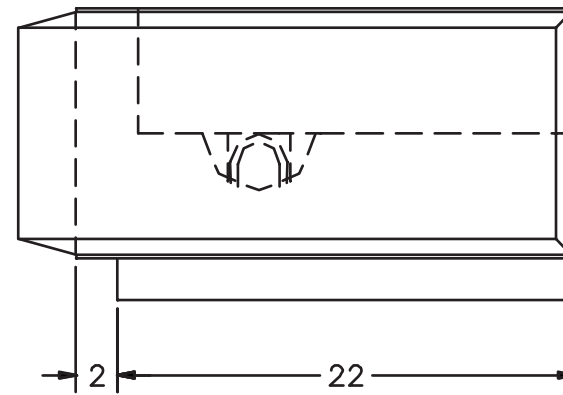
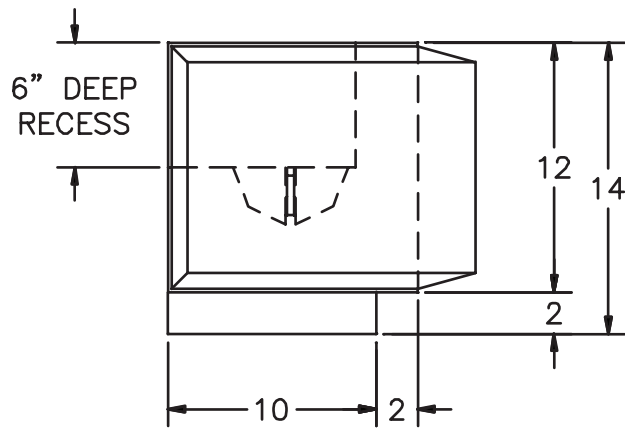
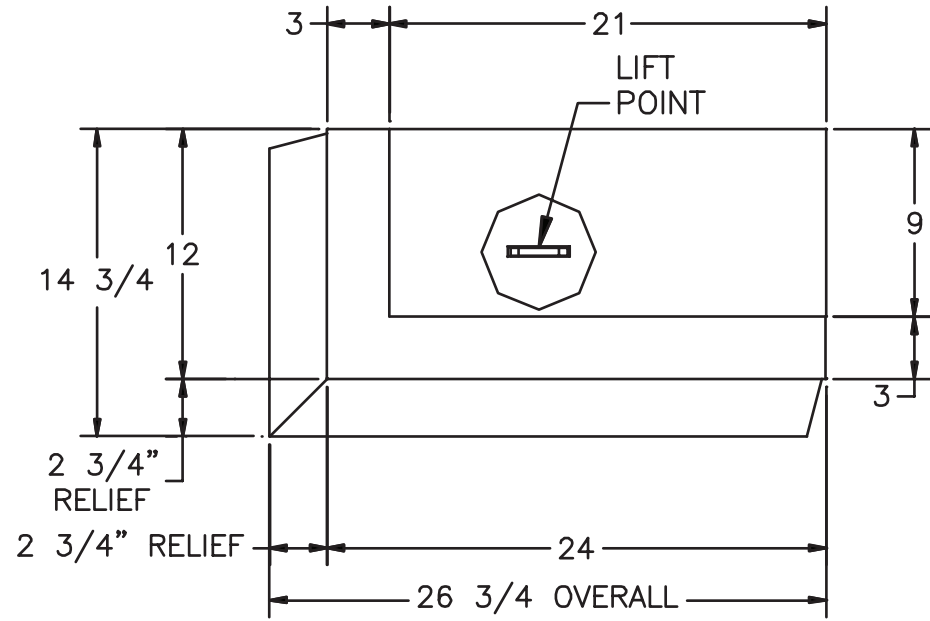
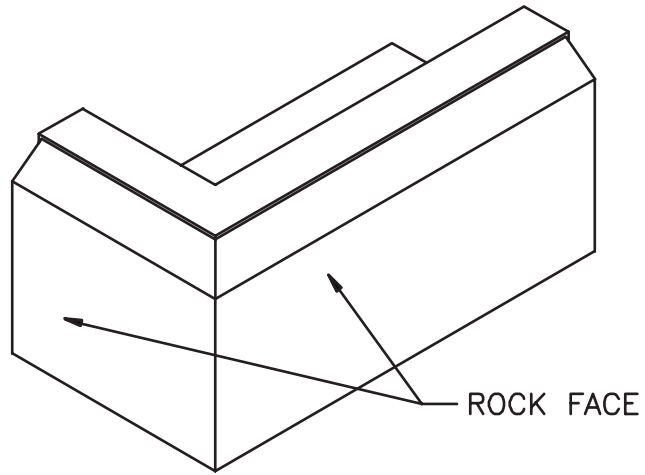

WEIGHT: 345 Lbs.
VOLUME: 2.30 Cft

■ MID-SIZE TOP CAP

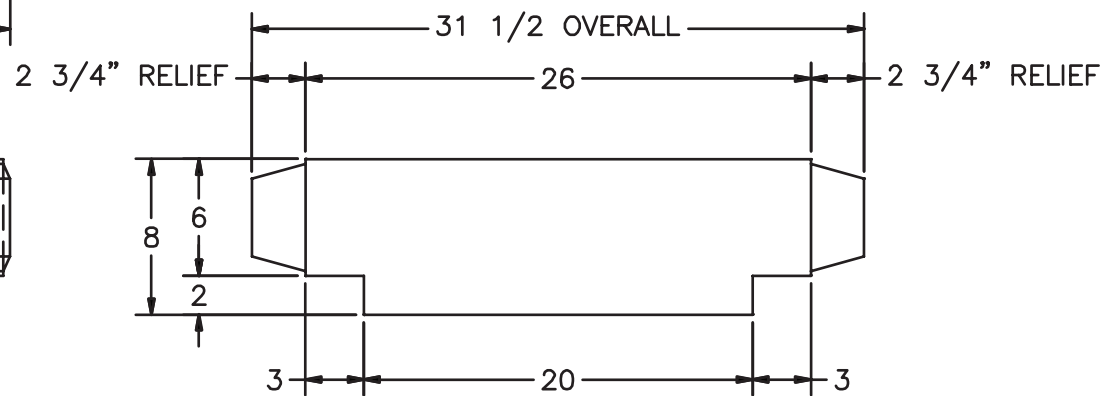
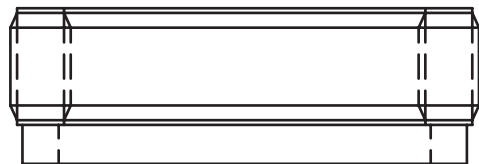
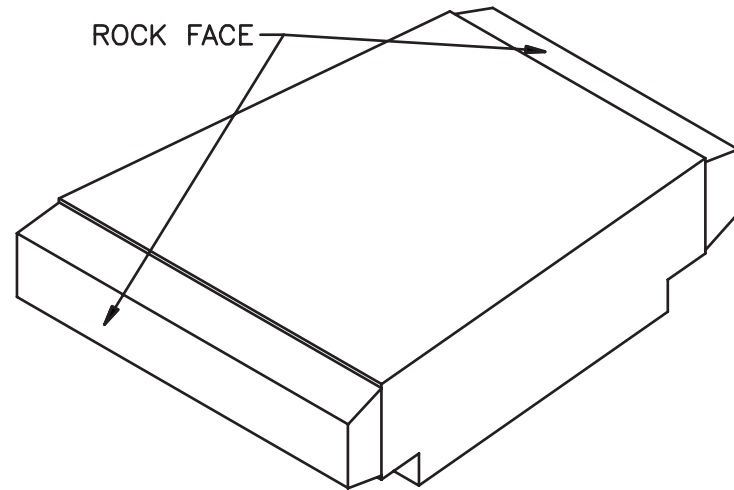
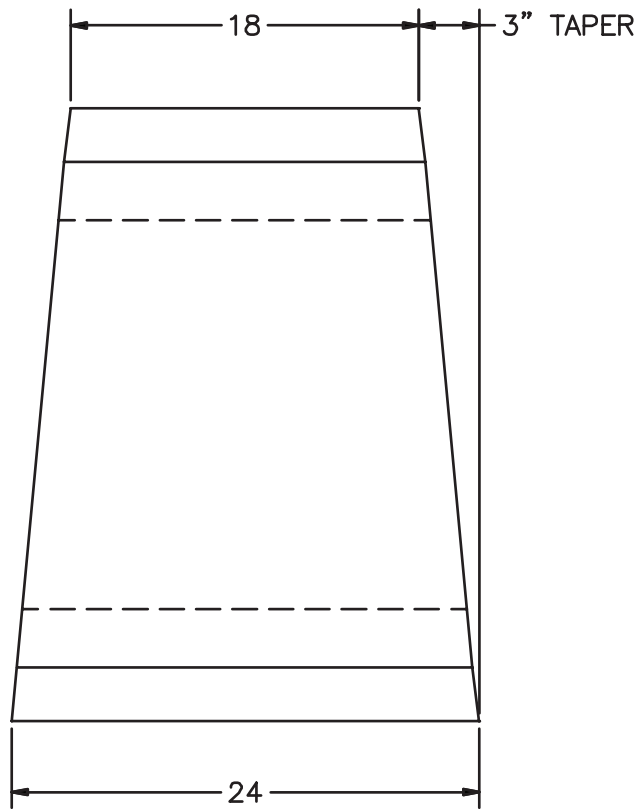

WEIGHT: 405 Lbs.
VOLUME: 2.70 Cft